

# **VOLLEYBALL**

## **SPIKE TRAINER**

**Model # VST-300**

For fixed-height Basketball  
Hoop Systems

**Assembly  
Instructions**

**Owner's  
Manual**

Basketball Hoop  
System Not Included

**Club Volleyball Gear**  
18434 Technology Drive, Morgan Hill, CA 95037

## **IF ASSISTANCE IS NEEDED**

CALL OUR CUSTOMER SERVICE DEPARTMENT at  
**1-888-737-8306**

HOURS: 8:00 a.m. to 5:00 p.m. Monday through Friday  
(Pacific Standard Time)



The shipping box contains all pieces necessary to assemble the VST-300 Volleyball Spike Trainer. The Hitting Arm, Volleyball Assembly, Rim Attachment Parts, Height Adjustment Arm and hardware parts bag(s) are shipped in one box approx. 43" long, 30" wide, & 6" tall.

### **Before Beginning Assembly**

**A.** Identify and inventory all parts. Keep the hardware bags and their contents separate. If any parts are missing, call our Customer Service Department.

**B.** Test fit all Knobs/Bolts by inserting them into their respective holes. If necessary, carefully scrape away any excess paint coating buildup from inside the holes. Do not scrape away all of the powder/paint coating. Bare metal may rust. You may need to pound some Bolts into place with a hammer or mallet.

# Step 1. Rim Mounting Assembly

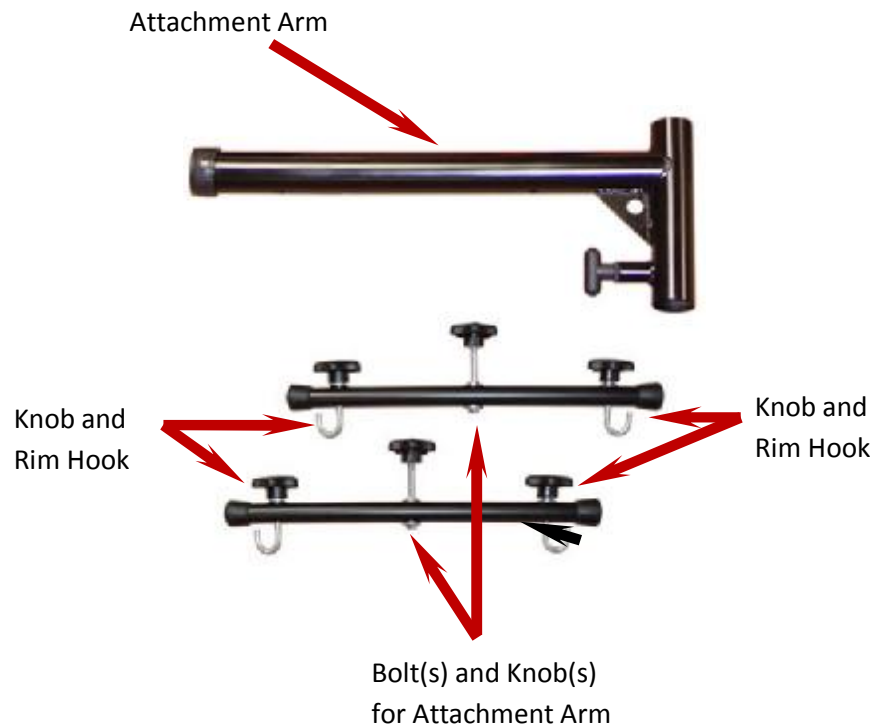

Unpack the pieces for the Rim Mounting Assembly and make sure you have everything needed to put it together. These are the parts required for **Step 1** (Rim Mounting Assembly)

- Attachment Arm (1 pcs)
- Knob and Rim Hooks (4 pcs)
- Bolt & Knob for Attachment Arm (2 pcs)
- Rim Mounting Bars (2 pcs)

When put together, the assembled **Rim Mounting Assembly** should look like this.



**Complete Rim Mounting Assembly**

Once you are finished with assembling the Rim Mounting Assembly, you can attach it to your fixed-height basketball system. **Important Note:** Your basketball system should be fully weighted to the basketball system manufacturers' requirement BEFORE attaching the VST-300 Volleyball Spike Trainer Rim Mounting Assembly.

The **Rim Mounting Assembly** attaches to the Basketball Rim of your fixed-height basketball hoop system using the four (4) Rim Mounting Hooks. They should be loosely attached to the **Rim Mounting Assembly** before you start this procedure.



1

Simply place the **Rim Mounting Assembly** over the top of your basketball rim. (Note: You may need to use a ladder for this step)

Use the Rim Hooks and Knobs to **securely fasten the VST-300 Rim Mounting Assembly** to your Basketball Rim

When finished attaching the **Rim Mounting Assembly** to your Basketball Rim, it should be oriented in this direction



**Note: Do NOT take your Rim off your basketball system.** It should already be attached to your Basketball Hoop System

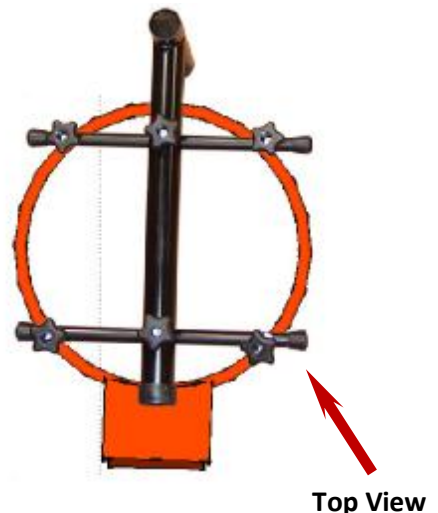

## Step 2. Attach the **Adjustment Arm** to the **Rim Mounting Assembly**.

2

- A. Simply insert the **Adjustment Arm** into bottom of the **Rim Mounting Assembly**,

**Important:** Make sure the **Height Adjustment Knob** clicks into place in one of the holes in the **Adjustment Arm** before letting go of **Height Adjustment Arm**.

- B. Once the **Height Adjustment Arm** is through the top the **Rim Mounting Assembly**, Insert the safety bolt, washer and nut into the hole near the top of the **Height Adjustment Arm**.



- C. Place the black **Plastic Cap** on the top of the **Height Adjustment Arm**

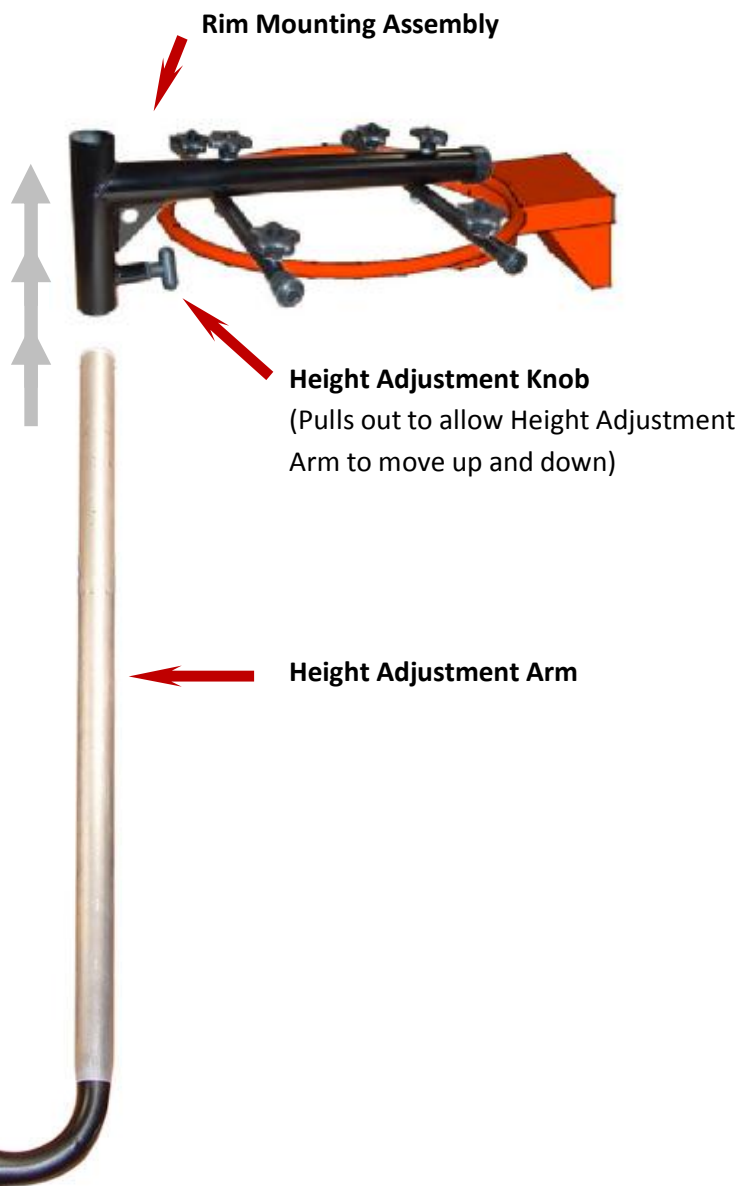

# Complete Rim Mount Height Adjustment Assembly (with Security Bolt, and Cap Installed)

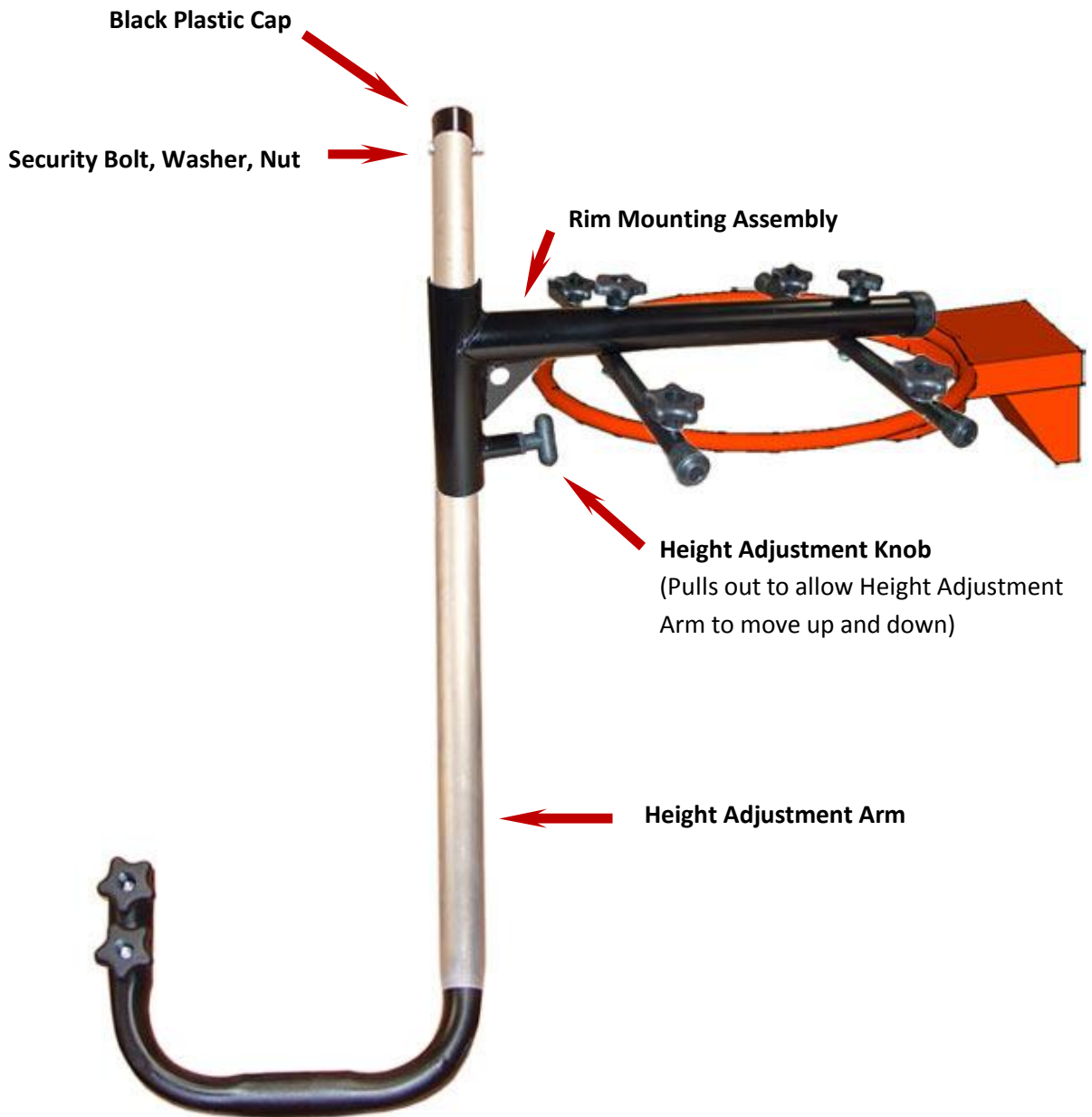

### **Step 3.** Attach the **Hitting Arm** to the **Rim Mount/Height Adjustable Assembly** completed in Step 2.

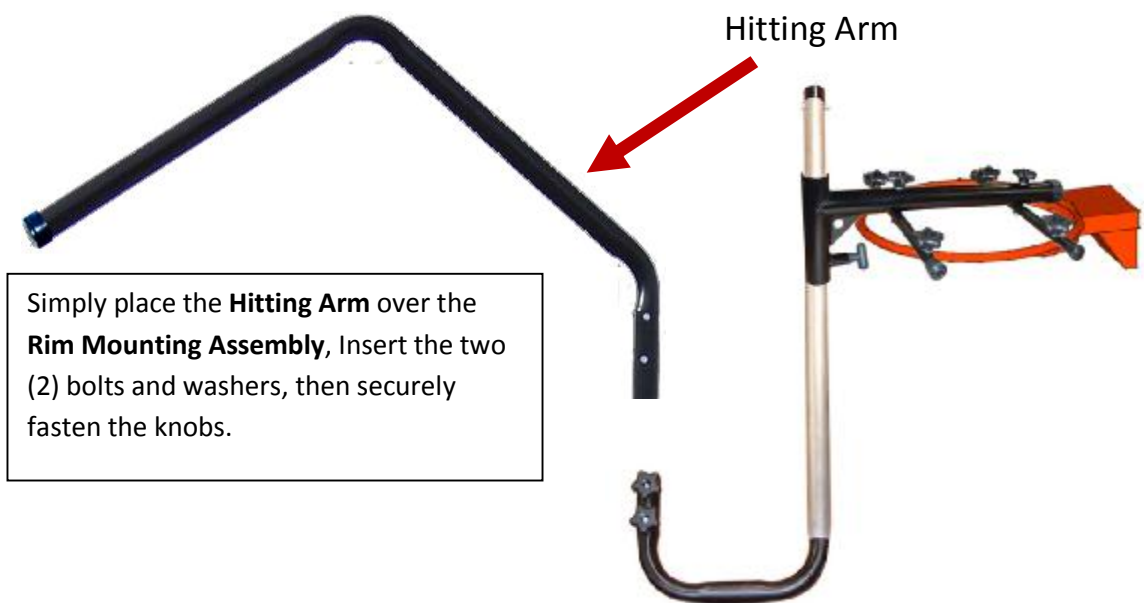

When finished attaching the **Hitting Arm** to the **Rim Mount /Height Adjustment Assembly** it should look like the picture below.



## Step 4. Attach the **Volleyball Assembly** to the **Hitting Arm**.

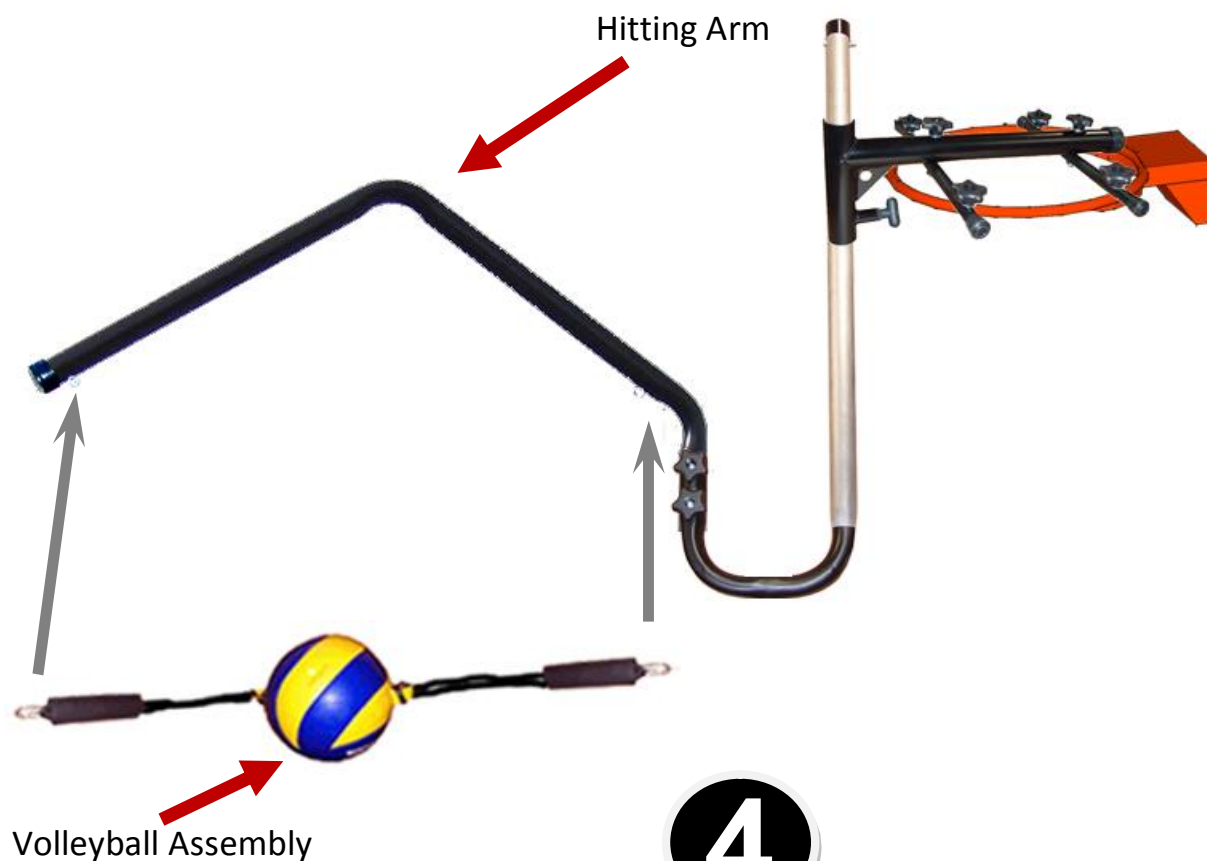

4

You're almost there. The last step is to attach the **Volleyball Assembly** to the **Hitting Arm**.

Secure the **Volleyball Assembly** to the **Hitting Arm** using the integrated quick-release fasteners on the ends of the Volleyball Assembly



**Congratulations. You're done.**



**Don't forget you need to make sure your Basketball Hoop System is capable of supporting the weight of the VST-300 (20 lbs) BEFORE using your VST-300 Volleyball Spike Trainer.**

**Have fun using your new VST-300 Volleyball Spike Trainer.**

# Adjusting Hitting Height

The VST-300 Volleyball Spike Trainer contains a height adjustment mechanism for lowering and raising the height of the Volleyball between 7 ½ and 10 feet.

Adjusting the hitting height of the Volleyball requires three things.

1. First, hold the bottom of the **Height Adjustment Arm** so the Assembly does not drop suddenly. **Continue Holding while height adjustment is made.**
2. Second, pull the spring-loaded **Height Adjustment Knob** so the pin disengages. Once disengaged, you can move the Height Adjustment Arm up or down.
3. Third, release the **Height Adjustment Knob** and make sure the Pin seats (clicks) into one of the predrilled holes on the Height Adjustment Arm. Make sure the Height Adjustment Arm is secured with the Height Adjustment Knob before releasing the Height Adjustment Arm.

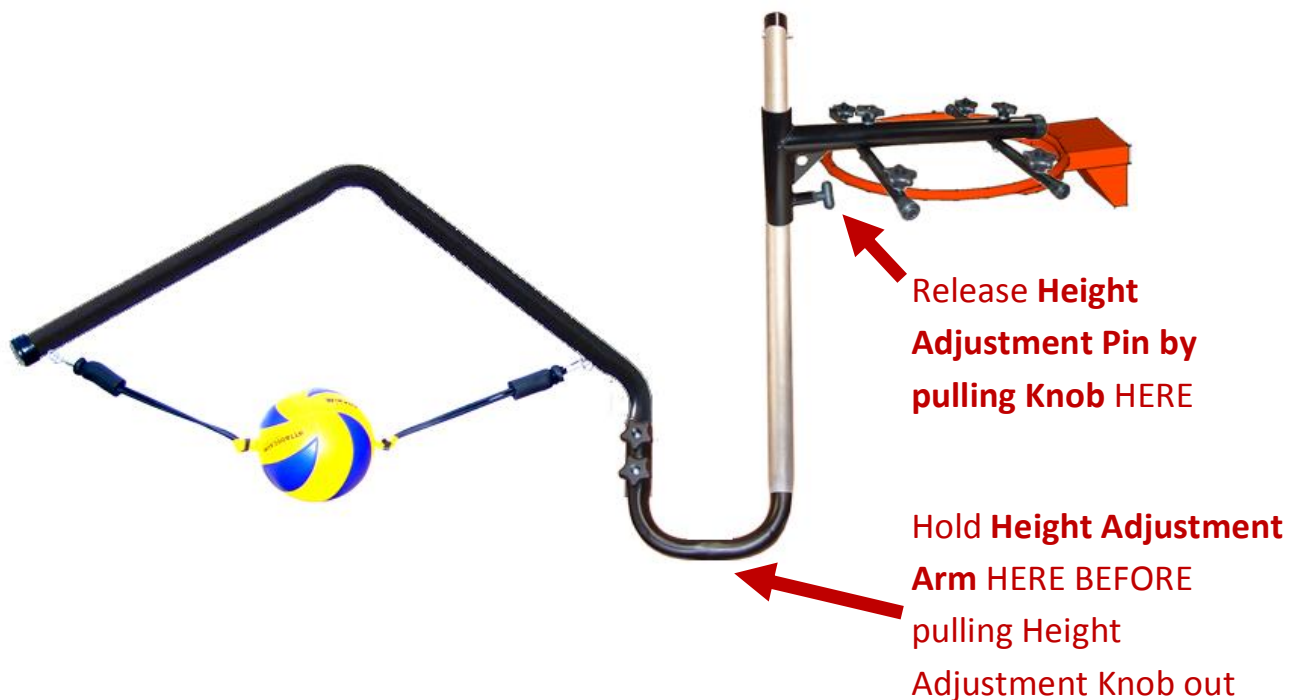

**FAILURE TO FOLLOW THESE WARNINGS  
MAY RESULT IN SERIOUS INJURY  
AND/OR PROPERTY DAMAGE.**

- Owners must ensure that all players know and follow these rules for safe operation of the system.
- When adjusting height or moving system, keep hands and fingers away from moving parts.
- Do not allow children to move or adjust system.
- Do not wear jewelry (rings, watches, necklaces, etc.) during play. Objects may entangle in hooks or your basketball net.
- Check system before each use for proper ballast, loose hardware, excessive wear, instability, and signs of corrosion and repair before use.

Never play on damaged equipment.

# Safety Instructions

***Owner must ensure that all players know and follow these rules for safe operation of the system.***

To ensure safety, do not attempt to assemble this system without following the instructions carefully. Check entire box and inside all packing material for parts and/ or additional instruction material. Before beginning assembly, read the instructions and identify parts using the hardware identifier and parts list in this document.

Proper and complete assembly, use and supervision are essential for proper orientation and to reduce the risk of accident or injury. A high probability of serious injury exists if this system is not installed, maintained, and operated properly.

**FAILURE TO FOLLOW THESE WARNINGS MAY RESULT IN SERIOUS INJURY OR PROPERTY DAMAGE AND WILL VOID WARRANTY.**

- If using a ladder during assembly, use extreme caution.
- Two capable adults are recommended for this operation.
- Check Knobs daily for tightness.
- Assemble the Rim Mounting Assembly and Hitting Arm sections properly. Failure to do so could cause the unit to become loose during play or transport.

***Most injuries are caused by misuse and/or not following instructions. Use caution when using this system.***

# VOLLEYBALL SPIKE TRAINER

## 3-YEAR LIMITED FACTORY WARRANTY

THE MANUFACTURER RESERVES THE RIGHT TO MAKE SUBSTITUTIONS TO WARRANTY CLAIMS IF PARTS ARE UNAVAILABLE OR OBSOLETE.

1. The Volleyball Spike Trainer is warranted to the original purchaser to be free from defects in material or workmanship for a period of three years from the date of original retail purchase. The word "defects" is defined as imperfections that impair the use of the product. Defects resulting from misuse, abuse or negligence will void this warranty. This warranty does not cover defects due to improper installation, alteration or accident. This warranty does not cover damage caused by vandalism, rusting, "acts of nature" or any other event beyond the control of the manufacturer.
2. This warranty is nontransferable and is expressly limited to the repair or replacement of defective Volleyball Spike Trainer equipment. If the equipment is defective within the terms of this warranty, Club Volleyball Gear will repair or replace defective parts at no cost to the purchaser. Shipping charges to and from the factory are not covered and are the responsibility of the purchaser. Labor charges and related expenses for removal, installation or replacement of the Volleyball Spike Trainer system or its components are not covered under this warranty.
3. This warranty does not cover scratching or scuffing of the product that may result from normal usage. In addition, defects resulting from intentional damage, negligence, unreasonable use or hanging from the Volleyball Assembly will void this warranty.
4. Liability for incidental or consequential damages is excluded to the extent permitted by law. While every attempt is made to embody the highest degree of safety in all equipment, freedom from injury cannot be guaranteed. The user assumes all risk of injury resulting from the use of this product. All merchandise is sold on this condition, and no representative of the company may waive or change this policy.
5. This product is not intended for institutional or commercial use; Club Volleyball Gear does not assume any liability for such use. Institutional or commercial use will void the warranty.
6. This warranty is expressly in lieu of all other warranties, expressed or implied, including warranties of merchantability or fitness for use. Neither Club Volleyball Gear, nor any representative assumes any other liability in connection with this product.

**ALL WARRANTY CLAIMS MUST BE ACCOMPANIED BY A SALES RECEIPT.**

REPORT PRODUCT DEFECTS IN WRITING TO:

Club Volleyball Gear, 18434 Technology Drive, Morgan Hill, CA 95037

Or call (888) 737-8306 M-F 8 a.m. to 5 p.m. PST.

Please include your dated sales receipt and photographs of damaged parts